

PB3MCOM2*

Piastra di base in all. con valvola di massima per montaggio PC3MCO**
 Block base in aluminium with relief valv for assembling PC3MCO**

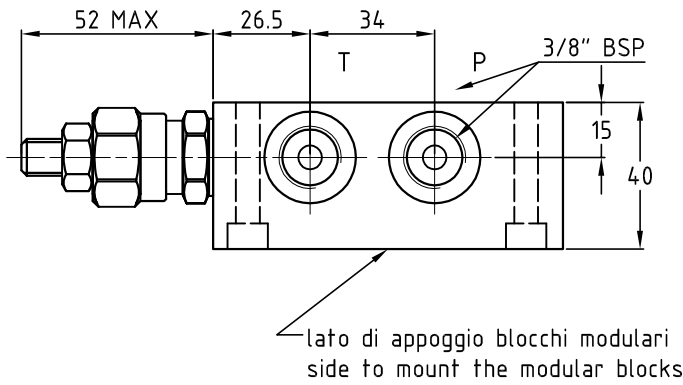
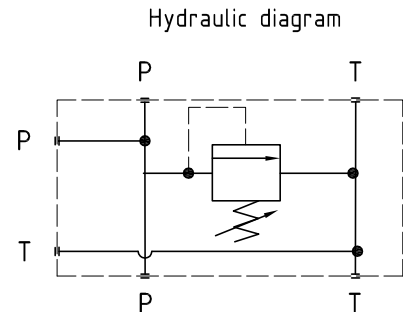
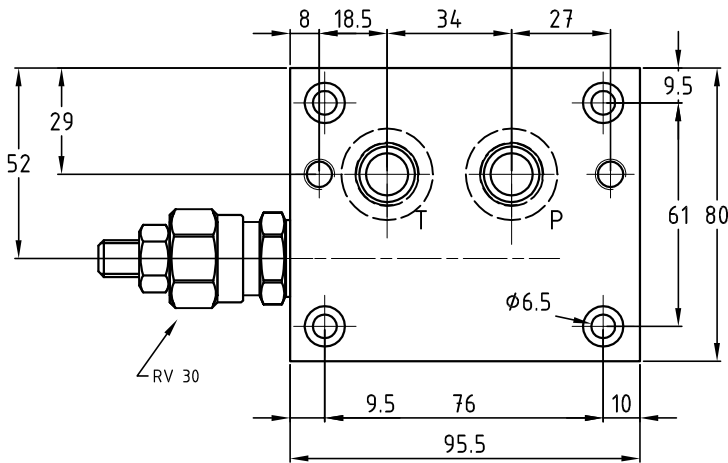

lato di appoggio blocchi modulari
 side to mount the modular blocks

peso/weight 0.90 Kg

Esempio di ordinazione - Ordering code

PB3 MCO M2 *

Piastra base in all. Cetop 03
 Base block in aluminium Cetop 03

Per mini centraline
 For mini powerpacks

Y=5÷55 bar A=25÷110 bar B=50÷250 bar
 Q=30 lt/m

Con valvola di max RV 30 (pag. M02)
 With relief valve RV 30 (page M02)