

We produce fluid power solutions



Product Overview

Fluid & Motion Control
Filter Solutions & Tank Systems
Sensors & Measurement
Fluid Management



GET IN VIRTUAL TOUCH!

Augmented Reality allows you to experience your ARGO-HYTOS product in an enhanced, up-close way. Discover functionality and efficiency from a new perspective. Install the AR app and off you go!



Quick and easy: Scan the QR code and install the app.

Alternatively: Open Google Play or the Apple App Store, search for "ARGO-HYTOS AR" and install. Click on the icon "ARGO-HYTOS AR" to start the app.

We wish you an exciting experience.

Discover your ARGO-HYTOS products at their best.
Move around the virtual device and also change the distance.

ARGO 
 **HYTOS**

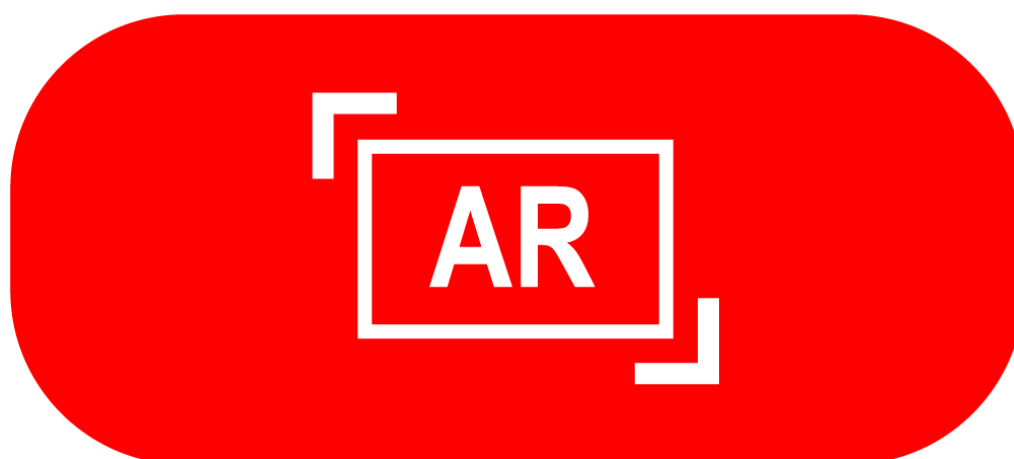

Content

Our products at a glance

About us

About ARGO-HYTOS	4
Application Engineering	5

Fluid & Motion Control

Directional Control Valves, Proportional Valves, Bankable modular valve assembly	7
Modular Valves, Screw-in Directional Valves, Pressure, Flow, Check and Motion Control Valves	8
Explosion Proof Valves, Hydraulic Integrated Circuits, Hydraulic Power Units	9
Application Solutions with Controls, Electronic Controllers, Hydraulic Drives	10
Connecting Plates, Manifolds, Pressure Switches and Transducers, Accessories	11

Filter Solutions & Tank Systems

Suction Filters, Built-in Suction Filters, Return Filters, Return-Suction Filters	13
Pressure Filters, High Pressure Filters, High Pressure Safety Filters, Stainless Steel High Pressure Filters	14
Filling and Ventilating Filters, Desiccant Breathers, Clogging Indicators, Oil Level Gauges with Thermometer, Oil Level Dipsticks	15
Customized Filter Solutions, Filter Elements	16
Injection Molded Plastic Tanks, HIT - Hybrid Integrated Tank®, Quick-Connect Hose Connection System	17

Sensors & Measurement

Portable Particle Counters, Stationary Particle Monitors, Lubrication Condition Sensors	19
Data Handling, Software	20

Fluid Management

Off-line Filters, Off-line Filter Units	22
Oil Service Units, Dewatering Units, Compact Filter Pack	23

A strong brand in fluid technology

We make your products better. Worldwide.



As a components and system supplier, ARGO-HYTOS is an essential part in the supply chain of the world market leaders when it comes to mobile working machinery and mechanical engineering. ARGO-HYTOS has established an international network of production and distribution companies to provide the full support our successful, global customers are accustomed to. We offer customer-oriented added value and expertise at the customers' location. In this era of increasingly complex technical issues, it is vital to have system partners who take a comprehensive, integrated approach to realizing a project, have extensive experience and can offer innovative solutions in the field of fluid power.

As a medium-sized family business with more than 1400 employees, ARGO-HYTOS has more than 70 years experience in Fluid & Motion Control and Filtration technology in mobile and industrial hydraulics. Especially in the mobile hydraulic sector, ARGO-HYTOS has developed into one of the innovation leaders.

We view ourselves as an international partner implementing innovative and individually designed system solutions together with our customers. The basis for this is a wide modular product range which can be flexibly expanded to customized solutions. We draw on our entire wealth of know-how and give new impetus to modern fluid power technology again and again. ARGO-HYTOS owns a number of patents and in many cases has set new standards in its industry.

With production companies in Germany, the Czech Republic, Poland, India and China as well as numerous own distribution and assembly companies, the ARGO-HYTOS Group is active worldwide. Additionally, we are cooperating with a network of professional service partners.

ARGO-HYTOS aims to make a substantial contribution to improve customer products and sustainably ensure significant customer benefit.

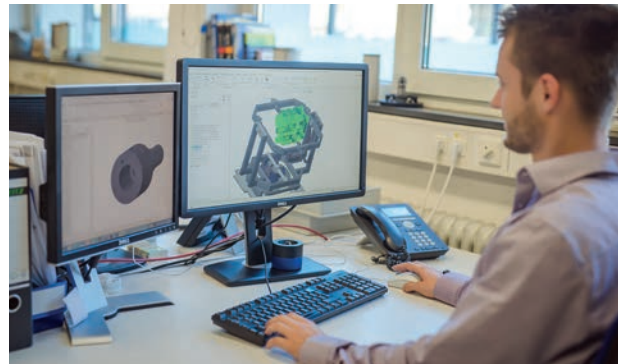

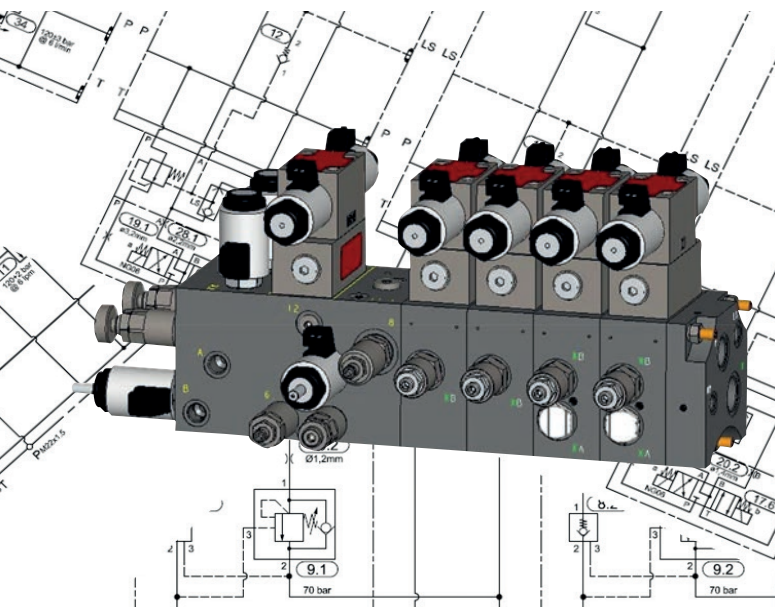

What APPLICATIONS Stands for...

- ... We develop cross-factory system solutions for varied applications: these solutions are based on combinations of already existing standard components of all products designed and produced within the ARGO-HYTOS Group.
- ... We supplement these system solutions with innovative products based on known and mastered technologies of the ARGO-HYTOS Group and with third-party products.
- ... Together with our customers we develop system solutions that reflect the customers' demands regarding purchasing, sales and marketing, production and the aftermarket.
- ... More and more, **total cost of ownership** is a selling point for our customers; we support that by providing solutions specifically tailored to regional needs and requirements.
- ... **Manufacturing expertise in valve, filtration, sensor and drive technology** makes us highly competent to find the best solution for our customers.

What APPLICATIONS Can Do for You...

- ... You determine and define functionality – we provide possible solutions.
- ... You want to redesign, modernize or adapt your machine to a regional market – we have the system knowledge, the components and the project planning competence to help you realize it.
- ... We combine for you local and central value-added shares in order to meet the highest requirements with regard to function safety, reliability and cost effectiveness.
- ... We support your development team in projects from initial inquiry up to the start of series production.
We maintain and observe highest internal standards in the processing of international projects in global core markets thanks to competent local contact persons and applications experts in our applications center.

We speak the language of our customer

An understanding of the application and the functionality is a prerequisite for quickly and efficiently identifying solutions.

The local sales organization brings the linguistic and cultural competence to the process of identifying the solution, applications engineering brings the technological expertise and applications experience. Thanks to our extensive applications know-how, we are able to assess functionalities and functional interaction; thus, we can competently advise our customers beyond the scope of their question(s).

We make your products better. **Worldwide.**



Directional Control Valves
Proportional Valves
Bankable Modular Valve Assembly
Modular Valves
Screw-in Directional Valves
Pressure, Flow, Check and Motion Control Valves
Explosion Proof Valves
Hydraulic Integrated Circuits
Hydraulic Power Units
Application Solutions with Controls
Electronic Controllers
Hydraulic Drives
Connecting Plates
Manifolds
Pressure Switches and Transducers
Accessories

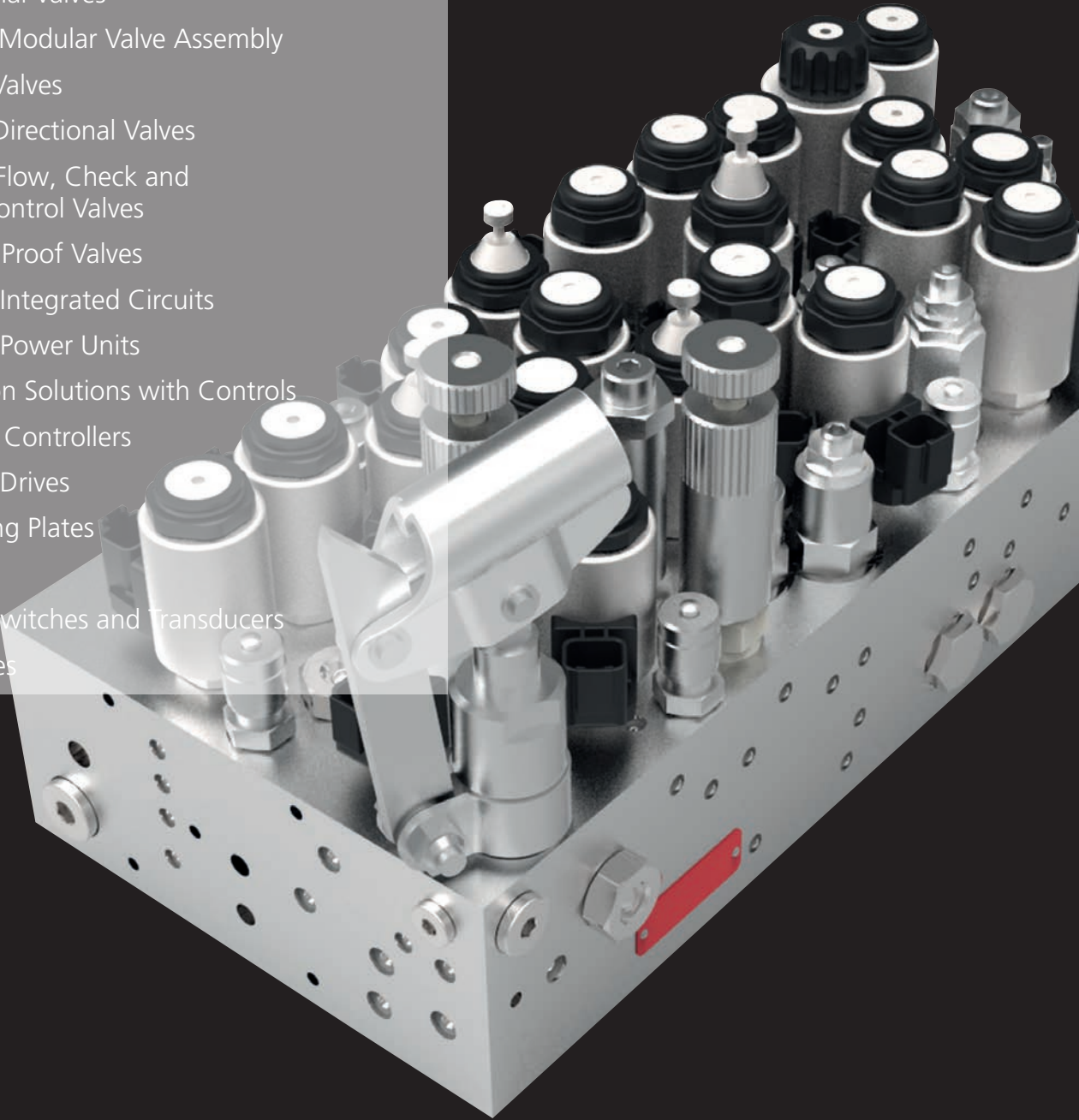

System Solutions

**You determine and define functionality –
We provide possible solutions.**

Directional Control Valves

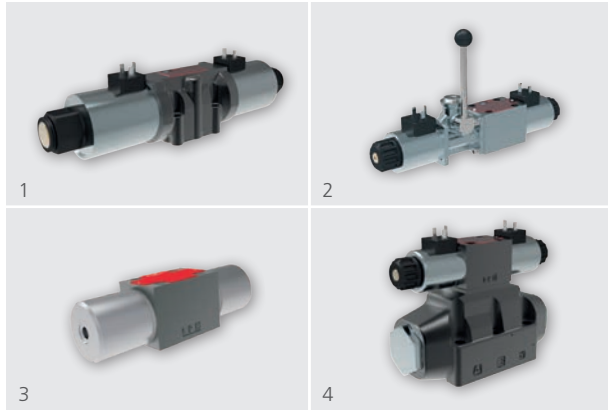

1 RPE4-10; 2 RPER3-06; 3 RPH3-06; 4 RNEH5-16

Features

- › Nominal flow rate: up to 600 l/min (158 gpm)
- › Operating pressure: up to 350/420 bar (5100/6100 psi)
- › Nominal size: CETOP 02, 03, 05, 07, 08
- › Voltage: 12, 14, 24, 27, 48, 205 V DC
24, 120, 230 V AC (50/60 Hz)
- › Connector plug: DIN/EN, Junior Timer, Deutsch
- › IP rating (EN 60529): 65, 67, 69K
- › Surface protection (ISO 9227): up to 520 h
- › UL, CSA certification
- › Special variants on request

Proportional Valves

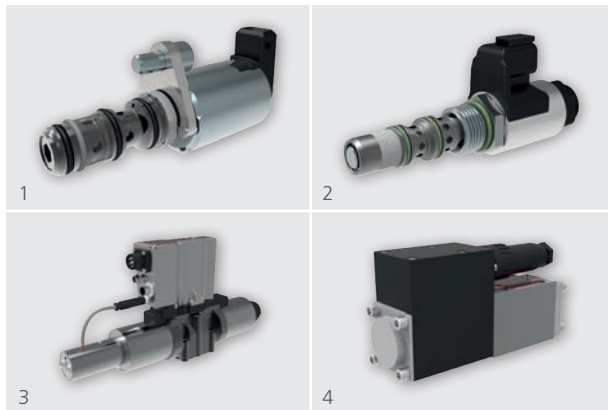

1 PP2P3-W3; 2 SP4P1-B4; 3 PRM9-10; 4 PRL2-06

Features

- › Nominal flow rate: up to 140 l/min (37 gpm)
- › Operating pressure: up to 350 bar (5100 psi)
- › Function: pressure relief/reducing and flow control
- › Type: CETOP, screw-in and slip-in cartridge
- › Voltage: 12, 14, 24, 27, 48, 205 V DC
24, 120, 230 V AC (50/60 Hz)
- › Connector plug: DIN/EN, Junior Timer, Deutsch
- › IP rating (EN 60529): 65, 67, 69K
- › Surface protection (ISO 9227): up to 520 h
- › CANopen connectivity possible / digital or analog on-board electronics / special variants on request

Bankable modular valve assembly

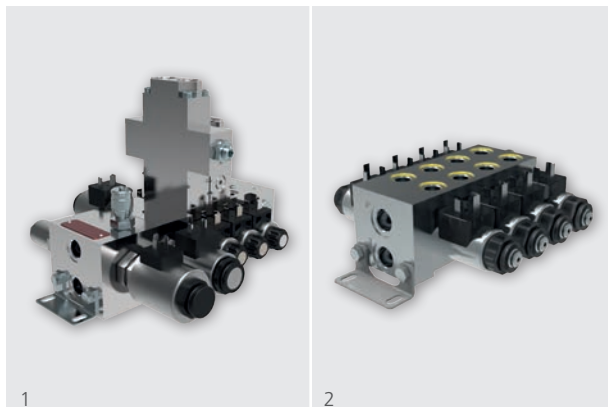

1 System Solutions; 2 RPEK

Features

- › Nominal flow rate: up to 20 l/min (5 gpm) - per section
- › Operating pressure: up to 250 bar (3600 psi)
- › Port sizes: G $\frac{1}{4}$, SAE6
- › Voltage: 12, 14, 24, 27 V DC
- › Connector plug: DIN/EN, Junior Timer, Deutsch
- › IP rating (EN 60529): 65, 67, 69K
- › Surface protection (ISO 9227): up to 520 h
- › Compact design, modular and space saving solution
- › Special variants on request

Modular Valves: CETOP

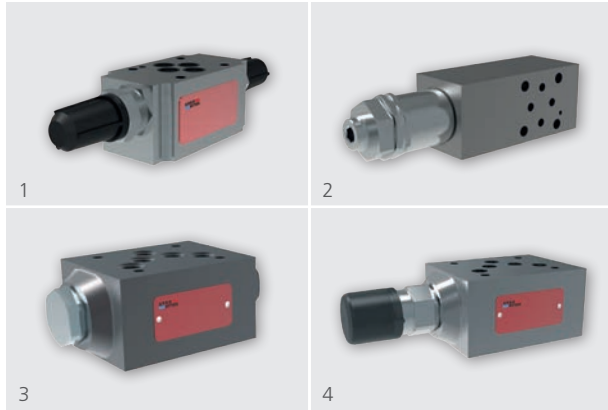

1 2VS3-06; 2 VPP2-04; 3 VRJ3-10; 4 VSO3-10

Features

- › Nominal flow rate: up to 100 l/min (26 gpm)
- › Operating pressure: up to 350 bar (5100 psi)
- › Nominal size: CETOP 02, 03, 05
- › Function: pressure relief/reducing, check and flow control
- › Surface protection (ISO 9227): up to 520 h
- › Various adjusting options

Screw-in Directional Valves

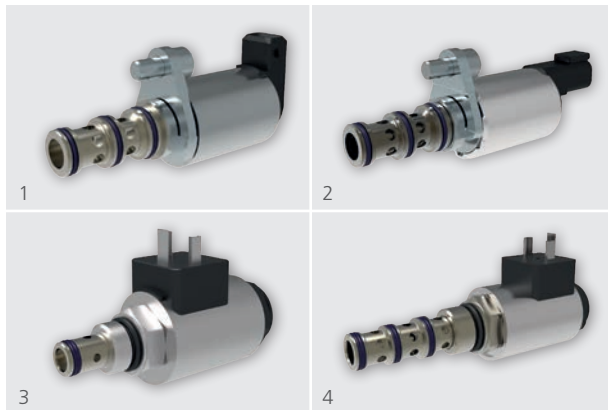

1 PD2E-W3; 2 PD2E-W3A; 3 SD2E-A2; 4 SD2E-B4

Features

- › Nominal flow rate: up to 150 l/min (40 gpm)
- › Operating pressure: up to 420 bar (6100 psi)
- › Type: screw-in and slip-in cartridge
- › Voltage: 12, 14, 24, 27 V DC
- › Connector plug: DIN/EN, Junior Timer, Deutsch
- › IP rating (EN 60529): 65, 67, 69K
- › Surface protection (ISO 9227): up to 520 h

Pressure, Flow, Check and Motion Control Valves



1 SD2H-LA3; 2 SO5A-BP3; 3 SP4A-B3; 4 SR1A-B2

Features

- › Nominal flow rate: up to 150 l/min (40 gpm)
- › Operating pressure: up to 350/420 bar (5100/6100 psi)
- › Function: pressure relief/reducing and flow control, check and motion control
- › Surface protection (ISO 9227): up to 520 h
- › Various adjusting options

Explosion Proof Valves

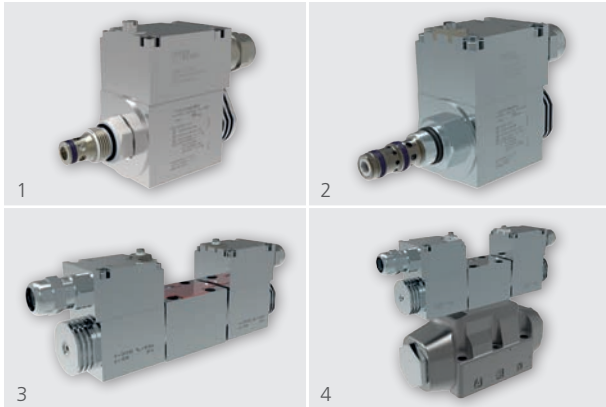

1 SD1EX-A2; 2 SD1EX-A3; 3 RPEX3-06; 4 RNEXH5-16

Features

- › Nominal flow rate: up to 600 l/min (158 gpm)
- › Operating pressure: up to 350 bar (5100 psi)
- › Type: CETOP and screw-in cartridge
- › Function: directional, proportional, flow and pressure control valve
- › Voltage: 12, 24, 48, 110 V DC
110, 230 V AC (50/60 Hz)
- › Acc. to directive ATEX 34/2014/EC
- › Temperature class: T4, T5, T6
- › Group: I, II (mining, dust and gas)
- › Various manual overrides

Hydraulic Integrated Circuits

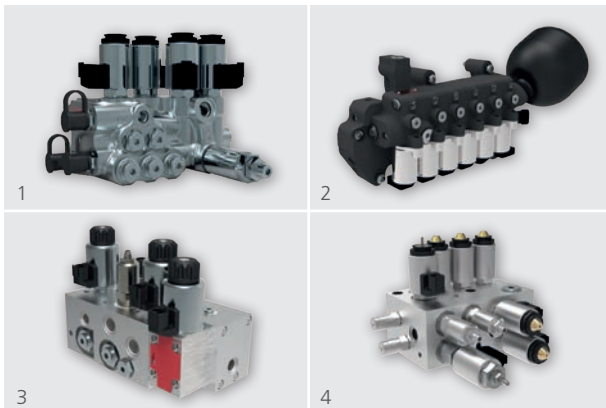

System Solution Blocks

Features

- › Nominal flow rate: up to 600 l/min (158 gpm)
- › Operating pressure: up to 420 bar (6100 psi)
- › Customized systems and subsystems
- › Best solution and efficiency oriented design
- › Surface protection (ISO 9227): up to 520 h

Hydraulic Power Units

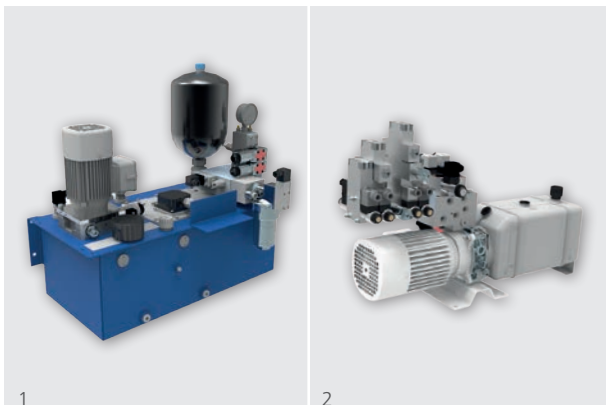

1 Power Pack; 2 SMA 05 Power Pack

Features

- › Nominal flow rate: up to 50 l/min (13 gpm)
- › Operating pressure: up to 250 bar (3600 psi)
- › Tank capacity: up to 250 liters (66 gallons)
- › Electric Motor Types: 1~110 V (50/60 Hz)
1~230 V (50/60 Hz)
3~400/460 V (50/60 Hz)
12/24 V DC
- › Special variants on request

Application Solutions with Controls



1

1 Modular Hydro-Pneumatic Suspension System

Modular Hydro-Pneumatic Suspension System (MHPS)

- › Improving suspension performance
- › Easy and fast adaptation to application
- › Electronic control unit, touch display and accumulators

Modular Load Sensing System

- › Designed for the complex and variable demands of mobile hydraulics needs
- › Standard modules easily adaptable to specific applications
- › Load sensing control of each working section

Electronic Controllers

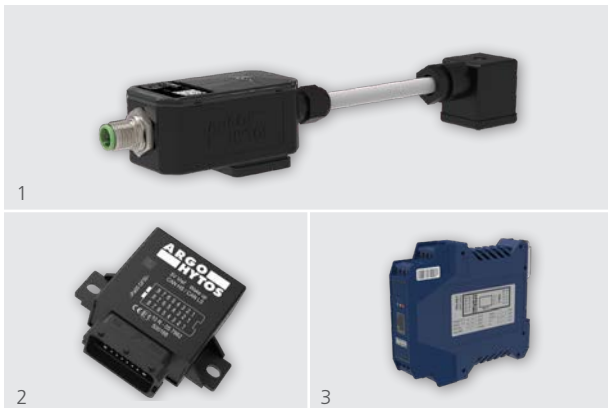

1

2

3

1 EL7; 2 Electronic Control Unit; 3 Digital Controller

Features

- › Amplifier for direct assembly on the valves
- › Digital or analog amplifier electronics
- › Plug-in or rail mounting amplifiers
- › Easy-to-use adjustments
- › User friendly software

Hydraulic Drives



1

2

1 GP2L; 2 GP3

Features

- › Displacement: up to 0.18-100 cm³/rev (cc/rev)
- › Operating pressure: up to 320 bar (5100 psi)
- › International standard flanges acc. to SAE, ISO, DIN, GOST
- › High quality aluminum alloys
- › High volumetric efficiency up to 98%
- › Lifetime 3000 working hours

Connecting Plates, Manifolds

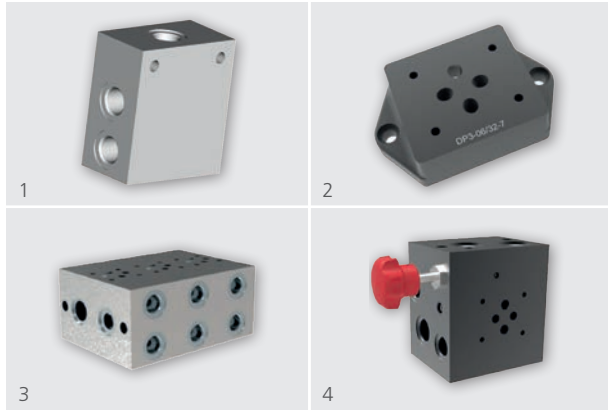

1 SB; 2 DP; 3 PD; 4 ZB

Features

- › Operating pressure: up to 320 bar (5100 psi)
- › Base plates
- › Serial plates
- › Sandwich plates
- › Sub-plates
- › Blanking plates
- › Surface protection (ISO 9227): up to 520 h

Pressure Switches and Transducers



1 PSCD; 2 TM1; 3 TS51; 4 TSE3-D

Features

- › Mechanical and electrical
- › Precise set point adjustment
- › Basic flange type expandable using connecting or modular plate
- › UL, CSA certification

Accessories

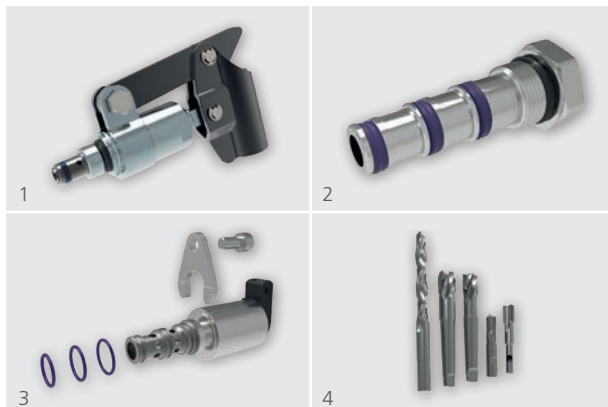

1 RCS; 2 SCP; 3 SP; 4 SMT

Features

- › Hand pumps
- › Cavity plugs
- › Spare parts
- › Stud and nut kits for vertical stacking assemblies
- › Cavity Form Tools
- › Surface protection (ISO 9227): up to 520 h

We make your products better. **Worldwide.**



- Suction Filters
- Built-in Suction Filters
- Return Filters
- Return-Suction Filters
- Pressure Filters
- High Pressure Filters
- High Pressure Safety Filters
- Stainless Steel High Pressure Filters
- Filling and Ventilating Filters
- Desiccant Breathers
- Clogging Indicators
- Oil Level Gauges with Thermometer
- Oil Level Dipsticks
- Customized Filter Solutions
- Filter Elements
- Injection Molded Plastic Tanks
- HIT - Hybrid Integrated Tank®
- Quick-Connect Hose Connection System

Filtration

Filter Solutions & Tank Systems -

Your success is our priority

Suction Filters & Built-in Suction Filters



1 AS 080; 2 S0.0426; 3 SFL 025; 4 ES 075

Features

- › Nominal flow rate: up to 350 l/min (92 gpm)
- › Fineness: 100...280 µm(c)
- › Hose connection: 32...60.5 Ø
- › Connection: G½...G2½
-12 SAE, -20 SAE
- › Suction filters to be installed in the suction line of the pump. With thread or hose connection. For in-tank, side-tank and in-line mounting.
- › Many series in High Performance and Lightline version available.

Return Filters



1 D 170; 2 E 103; 3 E 222; 4 E 503

Features

- › Nominal flow rate: up to 900 l/min (238 gpm)
- › Operating pressure: up to 10 bar (145 psi)
- › Fineness: 5...100 µm(c)
- › Hose connection: Ø 17.5...Ø 20.5
- › Connection: G½...G2½
SAE 2...SAE 2½
-12 SAE... -24 SAE
- › In-line, tank-top mounting or for mounting in a separate return flow tank section, optionally with integrated replaceable ventilating filter [2 µm(c)], or extension pipe and diffuser.
- › Many series in High Performance and Lightline version available.

Return-Suction Filters



1 E 084; 2 E 088; 3 E 198; 4 E 998

Features

- › Nominal flow rate: up to 850 l/min (225 gpm)
- › Operating pressure: up to 10 bar (145 psi)
- › Fineness: 10, 16 µm(c)
- › Connection: G¾...G1½
SAE 1½...SAE 2½
-12 SAE... -24 SAE
- › In-line or tank-top mounting, with boost pump connection (0.5 bar charge pressure) for hydrostatic drives.
- › Many series in High Performance and Lightline version available.

Pressure Filters

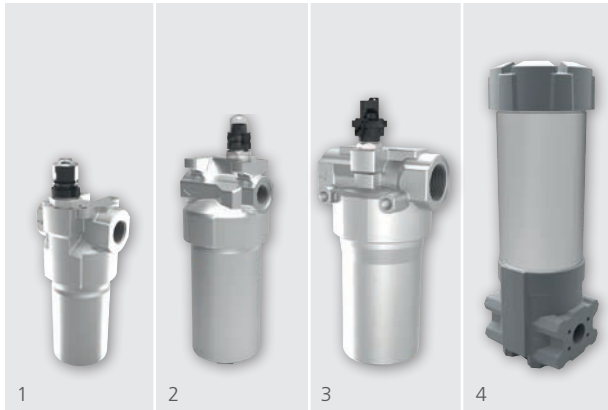

1 D 042; 2 D 072; 3 D 162; 4 FNL 1000

Features

- › Nominal flow rate: up to 2000 l/min (528 gpm)
- › Operating pressure: up to 100 bar (1450 psi)
- › Fineness: 5...30 µm(c)
- › Connection: G½...G2½
-8 SAE... -24 SAE
- › In-line mounting, optionally with electrical and / or optical clogging indicator.

High Pressure Filters & High Pressure Safety Filters

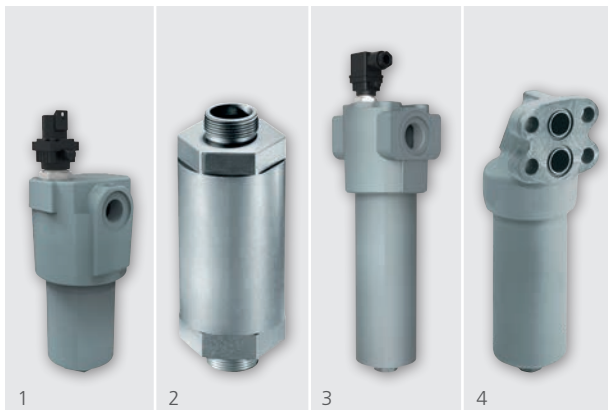

1 HD 049; 2 HD 081; 3 HD 172; 4 HD 414

Features

- › Nominal flow rate: up to 1000 l/min (264 gpm)
- › Operating pressure: up to 600 bar (8702 psi)
- › Fineness: 5...100 µm(c)
- › Flange connection: 2 x Ø 15, 2 x Ø 31
- › Connection: G½...G1½
-8 SAE... -24 SAE
SAE 1¼...SAE 2
- › Filter kits: M65 x 1.5...M108 x 1.5
- › Block mounting / inline mounting / flange connection, optionally reverse flow function, clogging indicator electrical and / or optical.

Stainless Steel High Pressure Filters



HFL 155

Features

- › Nominal flow rate: up to 200 l/min (53 gpm)
- › Pressure: up to 630 bar (9137 psi)
- › Fineness: 10...60 µm(c)
- › Connection: G½...G1
- › In-line mounting, with optical clogging indicators. Other designs are available on request. Due to stainless steel suitable for almost all media and applications.

Filling and Ventilating Filters & Desiccant Breathers



1 L1.0406; 2 L1.0506; 3 LE.0817; 4 LT.1021

Features

- › Air flow: up to 850 l/min (225 gpm)
- › Oil flow: up to 140 l/min (37 gpm)
- › Fineness: 2 µm(c)
- › Connection: G $\frac{3}{4}$
-12 SAE... -20 SAE
 $\frac{3}{4}$ - 14 NPT
M18 x 1.5...M60 x 2
- › Regulation of pressure changes in the reservoir and oil level monitoring. Options: Double check valve, dipstick, "Vandalism proof" types. Desiccant breathers additionally prevent the penetration of humidity into the tank.

Clogging Indicators



1 DG 062/DG 064; 2 DG 200; 3 DG 819; 4 DG 040/041

Manometers

- › Optical: green / red -0.25, 1.0 / 2.0 bar (-3.6, 14.5 / 29 psi)

Pressure switches

- › Electrical: Switching pressure -0.15, -0.25, 1.2...2.5 bar (-2.18, -3.6, 17.4...36 psi)

Differential pressure indicators

- › Optical: Response pressure 2...5 bar (29...73 psi)

Differential pressure switches

- › Electrical / optical Switching pressure 1.2...5 bar (17.4...72.5 psi)
- › Monitors the clogging condition of suction, return, return-suction, pressure and high-pressure filters.

Oil Level Gauges with Thermometer & Oil Level Dipsticks

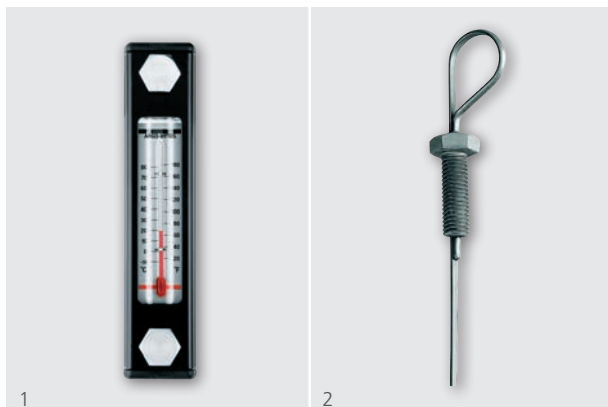

1 C5; 2 C4

Features Oil Level Gauges

- › Level range: 33...194 mm (1.3...7.6 inch)
- › Temperature scale: -10...+80 °C (+14...+176 °F)
- › Indicates the oil level and the oil temperature in hydraulic oil or lubricant reservoirs.

Features Oil Level Dipsticks

- › Dipstick length: 100...640 mm (3.94...25.2 inch)
- › Bolt thread: M10
- › Checks the oil level in hydraulic oil or lubricant reservoirs.

Customized Filter Solutions



1 E 077; 2 D 145; 3 E 599; 4 LS 250

Features

- › Customized filter and system solutions developed for special applications and designed in cooperation with our customers.

Filter Elements



1 Paper Element; 2 EXAPOR®MAX 3; 3 Screen Element; 4 Custom Labeled Element

Features

- › Glass Fiber Elements
 - EXAPOR®MAX 3
 - EXAPOR®Light
 - EXAPOR®SPARK PROTECT
 - EXAPOR®AQUA
- › Paper Elements
- › Screen Elements
- › Polyester Elements
- › ReFit-Elements
 - Glass Fiber Elements
 - MaxFit
 - LightFit

Injection Molded Plastic Tanks

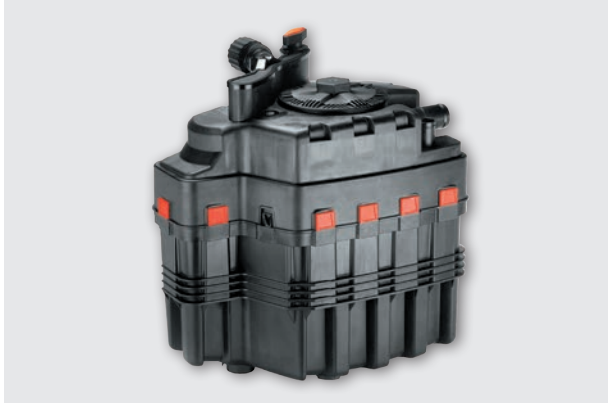

Injection Molded Tank

Features

- › Tank capacity: V_{\max} up to 60 l (16 gal)
- › Temperature: T_{\max} : -30 °C...+100 °C (-22 °F...+212 °F)
Short-term up to +120 °C (+248 °F)
- › Filter function: Return filter 10...30 $\mu\text{m(c)}$
Return-suction filter 10, 16 $\mu\text{m(c)}$
Suction filter 16...280 $\mu\text{m(c)}$
Ventilating filter 2 $\mu\text{m(c)}$
Filling filter 140...450 $\mu\text{m(c)}$
- › Customized design with integrated functions
- › Particularly attractive with large quantities required

HIT - Hybrid Integrated Tank®



Hybrid Tank

Features

- › Tank capacity: V_{\max} up to 150 l (40 gal)
- › Temperature: T_{\max} : -30 °C...+100 °C (-22...+212 °F)
Short-term up to +120 °C (+248 °F)
- › Filter function: Return filter 10...30 $\mu\text{m(c)}$
Return-suction filter 10, 16 $\mu\text{m(c)}$
Suction strainer 140...280 $\mu\text{m(c)}$
Ventilating filter 2 $\mu\text{m(c)}$
Filling filter 140...450 $\mu\text{m(c)}$
- › Customized design with integrated functions
- › Especially suitable for small quantities

Quick-Connect Hose Connection System



Quick-Connect System

Features

- › Temperature: T_{\max} : -30 °C...+100 °C (-22 °F...+212 °F)
Short-term up to +120 °C (+248 °F)
- › Pressure: up to 10 bar (14.5 psi)
- › Innovative hose connection technology
- › Assembly without any tools
- › Freely rotatable 360°

We make your products better. **Worldwide.**



Portable Particle Counters
Stationary Particle Monitors
Lubrication Condition Sensors
Data Handling
Software



Industry 4.0

Predictive Maintenance –
Enter the digital way of Condition Monitoring!

Portable Particle Counters



1 OPCOM Portable Oil Lab; 2 OPCOUNT

Features

- › The OPCOM Portable Oil Lab is a mobile oil laboratory with which the oil cleanliness and the oil condition in hydraulic and lubrication systems can be measured quickly and easily.
- › The OPCOUNT is a particle counter, designed for stationary or mobile operation. With its touch display and keypad it can be easily operated anywhere.

Stationary Particle Monitors



1 OPCOM; 2 OPCOM Phosphate Ester; 3 OPCOM without Display; 4 OPCOM FerroS

Features

- › The OPCOM Particle Monitor is a compact particle monitor for continuous monitoring of the contamination in hydraulic fluids and lubricants.
- › Special variants are available - for monitoring aggressive fluids, such as phosphate ester, or a version without display for harsh conditions, among others.
- › The OPCOM FerroS is an intelligent screw-in sensor to monitor ferromagnetic wear in hydraulic and lubrication systems.

Lubrication Condition Sensors



1 LubCos Level; 2 LubCos H₂O+ II

Features

- › Stationary screw-in sensor for the continuous determination of the oil condition, humidity and temperature in hydraulic and lubricating oils as well as for measuring the fluid level.

Data Handling



1 LubMon Connect; 2 LubMon Visu

Features

- › The LubMon Connect is a remote gateway for connection of ARGO-HYTOS sensors via a CANopen interface. The data of the connected sensors are automatically transferred to a web database and can be displayed or exported via a website.
- › LubMon Visu is a display unit, suitable for panel-mounting, with integrated data memory for connection of various sensors. ARGO-HYTOS offers a wide range of compatible sensors for monitoring of hydraulic and lubricating fluids. These are, amongst others, particle monitors, temperature, humidity and oil aging sensors.

Software

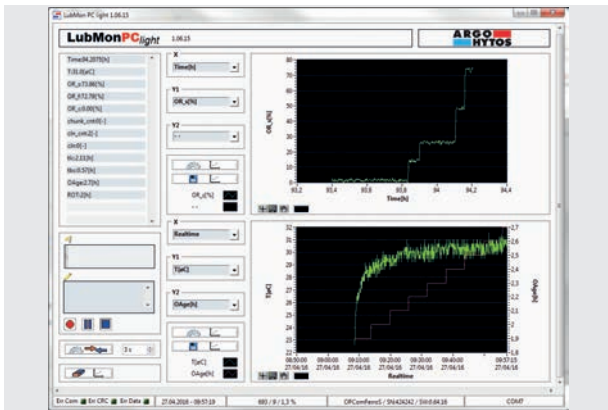

LubMon PClight

Features

- › The software LubMon PClight allows recording, storing and visualizing the incoming data from the condition sensors LubCos H₂O, LubCos H₂O+ II, LubCos Level, LubCos Vis+ and OPCOM Particle Monitor.

We make your products better. **Worldwide.**



- Off-line Filters
- Off-line Filters Units
- Oil Service Units
- Dewatering Units
- Compact Filter Pack



Oil Services

Fluid Management –
Keep your oil clean and smooth!

Off-line Filters

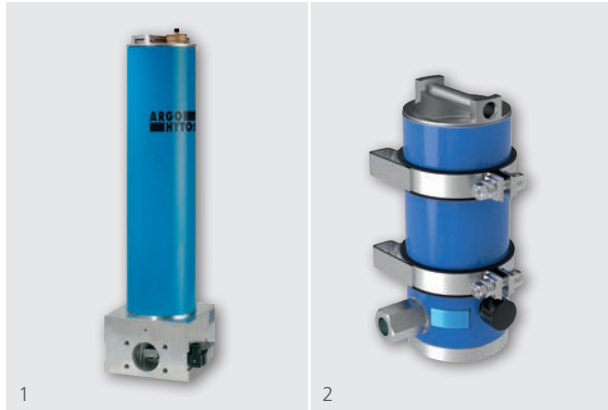

1 FN 300; 2 FNS 040

Features

- › Nominal flow rate: up to 650 l/min (172 gpm)
(with flow control valve: up to 6 l/min (1.6 gpm))
- › Operating pressure: up to 12 bar (174 psi)
(with flow control valve: up to 350 bar (5100 psi))
- › Fineness: 3, 5, 10 $\mu\text{m(c)}$
- › Connection: G $\frac{1}{4}$...G1, SAE 2 $\frac{1}{2}$
- › Off-line filters for application in low pressure circuits or with flow control valve for connection to the high pressure line
- › Special variants on request

Off-line Filter Units



1 FNAPC 045; 2 FNA 008

Features

- › Nominal flow rate: up to 45 l/min (12 gpm)
- › Operating pressure: up to 6 bar (90 psi)
- › Fineness: 3, 5, 10 $\mu\text{m(c)}$
- › Electric motor types: 1~110 V (50...60 Hz)
1~230 V (50...60 Hz)
3~400 V / 460 V (50...60 Hz)
24 V DC
- › Connection: up to G $\frac{1}{4}$
- › For first fit or for retrofitting in existing systems
- › Optionally with particle monitor and oil condition sensor

Oil Service Units

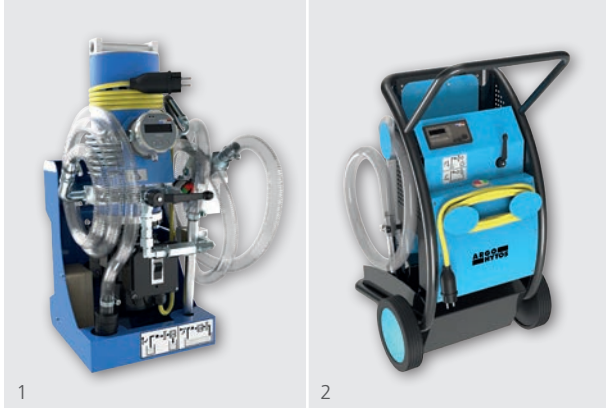

1 FAPC; 2 UMPC

Features

- › Nominal flow rate: up to 70 l/min (18.5 gpm)
- › Operating pressure: up to 6 bar (90 psi)
- › Fineness: 3, 5, 10, 16 µm(c)
- › Electric motor types: 1~110 V (50...60 Hz)
1~230 V (50...60 Hz)
3~400 V / 460 V (50...60 Hz)
24 V DC
- › Filter Units for cleaning in off-line filtration or for filling systems with ultra-fine filter elements
Optionally with particle monitor
- › Special variants on request

Dewatering Units

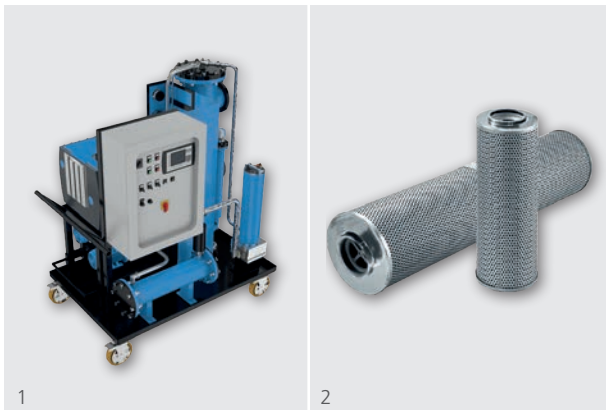

1 OPS 550; 2 Exapor AQUA

Features

- › Nominal flow rate: up to 50 l/min (13.2 gpm)
- › Operating pressure: up to 4 bar (60 psi)
- › Fineness: 3, 5, 10 µm(c)
- › With dewatering units, large quantities of free water can be removed from the oil.
The water content is constantly monitored with the water sensor LubCos H₂O+ II.

Water Absorbing Filter Elements

- › Small quantities of remaining water can be withdrawn by water absorbing filter elements. Water absorbing filter elements fit in standard versions of off-line filters and filter units.

Compact Filter Pack CFP 03 - exclusive solution for small tanks

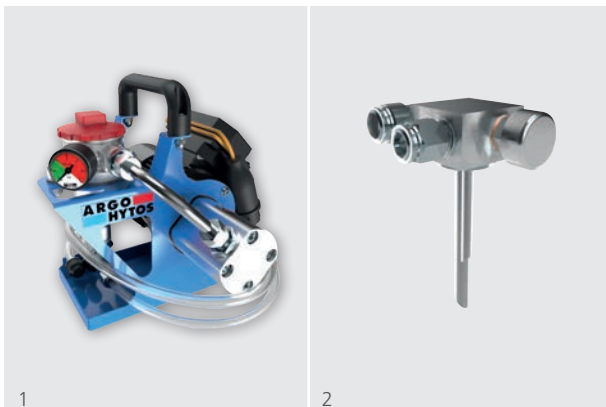

1 CFP 03; 2 Suction-Return Set

Features

- › Ergonomic design
- › Ultralight and compact
- › Multi-purpose system
- › Simplifies servicing of small power packs
- › Nominal flow rate up to 4 l/min (1 gpm)
- › Working pressure 3.5 bar (50 psi)
- › Weight 9 kg
- › Filter fineness 5, 10, 16 µm
- › Electric motor with switch
- › Hydraulic hoses included
- › Additional adapter for servicing of tanks with only one available connecting port

International

ARGO-HYTOS worldwide

Benelux	ARGO-HYTOS B.V.	info.benelux@argo-hytos.com
Brazil	ARGO-HYTOS AT Fluid Power Systems LTDA.	info.br@argo-hytos.com
China	ARGO-HYTOS Fluid Power Systems	info.cn@argo-hytos.com
Czech Republic	ARGO-HYTOS s.r.o. ARGO-HYTOS Protech s.r.o	info.cz@argo-hytos.com info.protech@argo-hytos.com
France	ARGO-HYTOS SARL	info.fr@argo-hytos.com
Germany	ARGO-HYTOS GMBH	info.de@argo-hytos.com
Great Britain	ARGO-HYTOS Ltd.	info.uk@argo-hytos.com
Hong Kong	ARGO-HYTOS Hong Kong Ltd.	info.hk@argo-hytos.com
India	ARGO-HYTOS PVT. LTD.	info.in@argo-hytos.com
Italy	ARGO-HYTOS S.r.l.	info.it@argo-hytos.com
Poland	ARGO-HYTOS Polska spz o.o.	info.pl@argo-hytos.com
Russia	ARGO-HYTOS LLC	info.ru@argo-hytos.com
Sweden	ARGO-HYTOS Nordic AB	info.se@argo-hytos.com
Turkey	ARGO-HYTOS Hid Ekip. San. ve Tic Ltd. Sti.	info.tr@argo-hytos.com
USA	ARGO-HYTOS Inc.	info.us@argo-hytos.com

